

Classic Turnstiles

Interior & Exterior Application
CS-79/CD-79/CP-79, CW-79 • HG-81

Style and durability make the Classic waist high units unique in the industry. Crafted from aluminum for rust-free indoor or outdoor applications, the Classic Series turnstiles are smooth operating units, so exceptional in materials and workmanship that *Modern Metals Magazine* honored them with an award for excellence in the field of nonferrous mold casting.



Classic CS-79

The **Classic CS-79 Turnstile** has a solid, rust proof aluminum housing and cover cap with a truncated 3-arm head that accepts steel-reinforced, molded polymer arms.

Measurements (housing):

Height: 37" high
Depth: 11' to 14"
Width: 26"

Optional variations include:

CD-79: Twin version of the CS-79

CP-79: Portable version of the CS-79

CW-79: Wall-mount unit without the bottom portion of the housing to enable mounting at any height. Available in silver, matte gray, black or beige with custom colors available. Cap and arm assemblies are black.



Classic HG-81

The classic handicapped gate.

Features the same basic construction and housing dimensions as the CS-79 with a single horizontal solid rigid urethane arm with internal metal reinforcement shaft (optional length for 90 degree movement in both directions). Safe, soft Feather-Touch operation prevents injury. Control head is mounted in the top cover. Available in silver, matte gray, black or beige with custom colors available. Cap and arm assemblies are black.

Security Across the Globe

For half a century, Sentronic International has been the trusted name in pedestrian control equipment. From our headquarters in Ohio, the company ships access solutions worldwide – whether your project requires full-height turnstiles, waist-high units, or matching ADA accessible gates we can provide the best available. Crafted in Aluminum or Stainless, our diverse product line offers state-of-the art technology – from card readers to biometric scanning capability.

 Made in Ohio...
In-Service World-Wide



Silvadillo and Gray



UniCream and Black Pearl



SENTRONIC® International

P.O. Box 815 • Brunswick, OH 44212-0815 • Ph: 330.225.3029 • Fax: 330.225.3009 • Toll-Free Ph: 888.225.3029
E-mail: sales@sentronicinternational.com • www.sentronicinternational.com

Classic Turnstiles

Interior & Exterior Application

CS-79/CD-79/CP-79, CW-79 • HG-81

Applications:

Ideal for both indoor or outdoor applications, the Classic high speed traffic control devices offer patented features and the latest technology in rust-free materials, design and quality workmanship. Modern Metals Magazine honored these turnstiles with an award for excellence in the field of nonferrous mold casting.

Noiseless

Our patented undulating cam mechanism with unique locking principle, self adjusts to wear and reduces moving parts to a minimum.

Self Positioning

A proven functional principle permits shock and static-free molded barrier arms to move in to proper horizontal rest position or indent at 120° without reversing, stopping or jamming in a dangerous halfcocked position.

CS-79 Turnstile

Solid rustproof aluminum housing and cover cap with truncated 3-arm head accepting steel-reinforced molded polymer arms.

Housing is 37" high, 11" to 14" deep and 26" wide. Clear 90° open passageway is 16" long.

CD-79: twin version of the CS-79.

CP-79: portable version of the CS-79.

CW-79 Wall Mount Unit is the same as the CS-79 with out the bottom portion of the housing to permit wall mounting at any desired height.

HG-81 Handicapped Gate

Same basic construction and housing dimensions as CS-79 with a single horizontal arm of optional length for 90° movement in both directions. Safe, soft Feather-Touch® operation prevents injury. Control head is mounted to the top cover.

Installation

Detailed drawings, installation and maintenance instructions shall be furnished by the manufacturer.

Materials - Classic® Turnstile

The housing and cover cap are die-cast aluminum. The arms are one-piece, solid molded rigid urethane with internal metal reinforcing shaft that connects to the control mechanism.

Materials - Classic® Handicap Turnstile

Same as above, except the single horizontal arm (optional length) is 6005-T6 extruded aluminum with powder coated finish.

Optional Handicap Gate Arm

For added security, this arm is available with rounded corner framework of 3/4" OD tubular steel and three vertical rails.

Control Mechanism

Advanced modular design is equipped with auto indexing, shock suppression, permanently lubricated bearings, hardened alloy cams and locking bars.

Finish

Pedestal standard finishes silver, matte gray, or beige with custom colors available. Cap and arm assemblies are black.

Pedestrian Flow Movements

Standard movements can be ordered free flow, no flow, and controlled flow each separate direction. Electronically controlled systems can be ordered fail-lock or fail-open upon power failure. Standard setting is fail-lock.

CONTROL OPTIONS

Lock

Includes 24 VDC power supply, solenoid, Lock assembly, logic controller with card reader interface.

Input Modules

Card readers, fingerprint scanners, push buttons, token acceptors, consult factory for other options.

Keylock

Control direction of travel manually by key lock or unlock; may be used to override electronic lock controls.

Counter

Reset or non-reset electronic registering counter and anti-coincidence summer for banks and turnstiles.

Indicators

Traffic light control module with red, yellow, green LED's and audible alarms.

Accessories

Stainless steel railings, posts, retractable tape barriers - send drawing for price quotation.

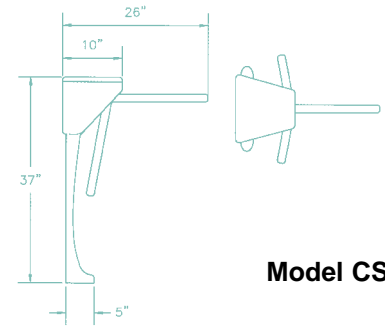

Model CS-79

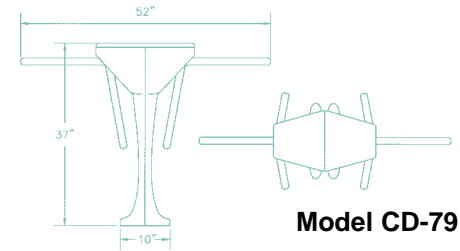

Model CD-79

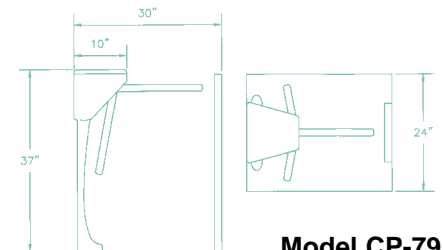

Model CP-79

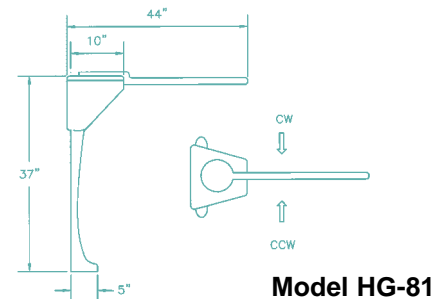

Model HG-81

Electrical Specifications:

Command module input 110-240 VAC (2 amp-1 amp) 50-60 Hz; control voltage 24 VDC.

All electrical components are UL recognized and CSA certified.

Warranty:

Units are warranted against defects in materials and workmanship for a period of one year from date of delivery. See warranty information for specific details.



SENTRONIC® International

P.O. Box 815 • Brunswick, OH 44212-0815 • Ph: 330.225.3029 • Fax: 330.225.3009 • Toll-Free Ph: 888.225.3029

E-mail: sales@sentronicinternational.com • www.sentronicinternational.com